



• Victory + Galaxy 130

www.accupack.in

Introducing a partnership to tune up your packaging performance



- Very compact footprint
- 400 blisters/min
- Operator friendly design

- 130 cartons/min
- Very compact footprint
- Exceptional price/performance ratio

Key Highlights

- European Design
- A fully servo-driven mechanism for high speed and better accuracy
- In-built plug assist for intricate forms and special materials
- Multiple feeding solutions
- Dedicated embossing station
- Cold forming & PP function
- Ready for Track & Trace integration
- Minimal noise levels and vibrations
- Positive carton pick-up with three rotary arms
- No friction to carton while movement
- Multiple options available as different closing systems and leaflet feeders, camera systems, glue closure, variable data printing and many more
- Easy to clean due to cGMP compliant balcony design
- Low Life-Cycle-Costs
- Outstanding delivery times due to lean production processes
- 24/7 service concept

Victory (Technical Specifications)

• Output (Max)	:	400 Blisters/min
• Mode Of Operation	:	Double Lane
• Sealing Principle	:	Platen Sealing
• Blister Pack Length (Max)	:	252 mm
• Blister Pack Width (Max)	:	90 mm
• Advance (Max)	:	180 mm
• Blister Forming Depth (Max)	:	12 mm
• Thermo Forming Material	:	Laminated Al foils, PVC, PVC/PVDC, Duplex, Triplex, PVC/Aclar, PP
• Lidding Material	:	Hard Al, Soft Al, Paper Al, CR foil, Laminated Paper
• Machine Forming Speed (Max)	:	50 Cycles/min
• Machine Cutting Speed (Max)	:	200 Strokes/min
• PVC Film Width (Max)	:	260 mm
• Alu Foil Width (Max)	:	258 mm
• Weight	:	4.500 kg

Galaxy 130 (Technical Specifications)

• Output (Max)	:	130 Cartons/min
• Mode Of Operation	:	Intermittent motion
• Scope Of Application	:	Blisters, bottles, tubes, vial, tray, ampoules
• Blister Dispensing Speed (Max)	:	390 Blisters/min
• Carton Size Range		
• Carton Width - A - (Min/Max)	:	15 - 95 mm
• Carton Height - B - (Min/Max)	:	15 - 70 mm
• Carton Length - C - (Min/Max)	:	70 - 160 mm
• Types Of Closure	:	Tuck-in, hotmelt
• Weight	:	1.400 Kg

*We also provide Line Configuration: U-Type/C-Type/Z-Type

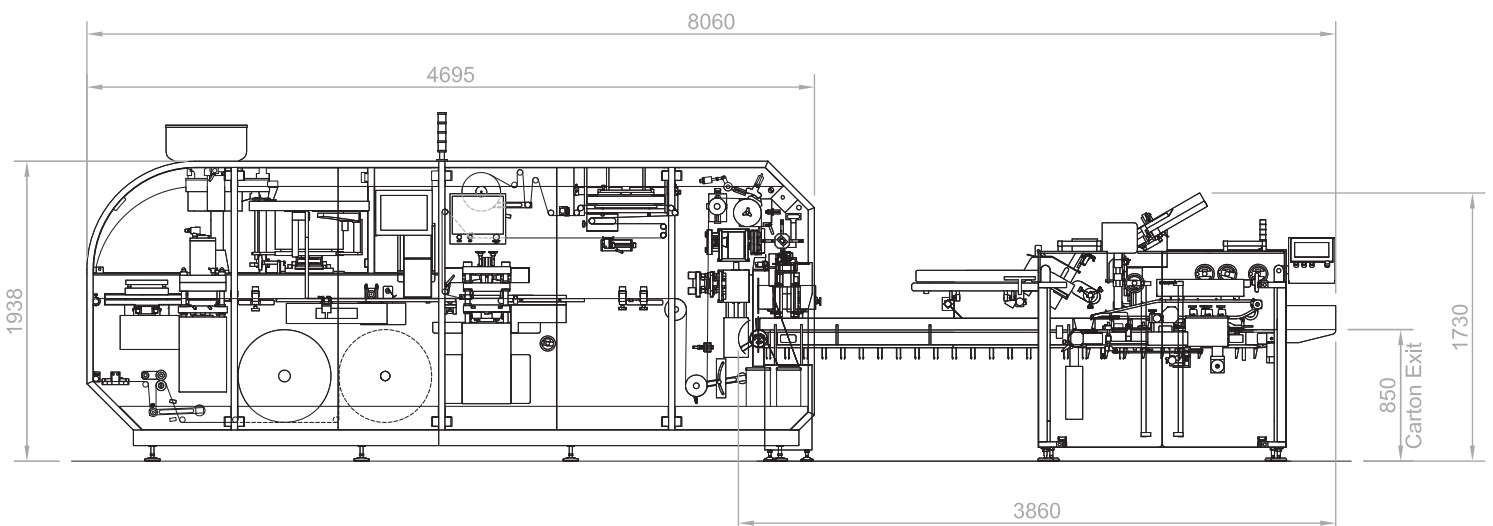

Thoughtfully designed in **Europe**, Smartly engineered in **India**.

India's leading manufacturer
of Blister Packaging
& Cartoning Machines.





Accupack Engineering Pvt. Ltd. (Europe)

Obere Langgasse 9, 67346 Speyer, Germany.

+49 1523 4788009

sales@accupackeurope.com

Accupack Engineering Pvt. Ltd.

H.O: 6A, TTC Industrial Area, MIDC,
Rabale, Navi Mumbai 400701, India.

+91 91369 99168

marketing@accupack.in

Moving Responsibly Towards A Sustainable Future

**Get your quote within 48 hours!
We are EASY TO DEAL with!**

- Machines • Format Parts • Software • Service